



HAYTER

MAKERS OF THE FINEST MOWERS

Spirit 41 Electric

CODE

615E



OWNER'S HANDBOOK

Original Version (EN)
ISSUE: 14.06.11

PART NUMBER: 111-5122 (A)

CONTENTS

Contents	2	Mower Maintenance	10 - 11
Introduction	3	- Grassbag	10
Specifications / Main Features	4	- Deck Housing	10
Safety Precautions	5 - 6	- Securing Nuts and Bolts	10
- Safety Alert Symbol	5	- Lubrication	10
- Training	5	- Cutterblade Removal	10 - 11
- Preparation	5	- Cutterblade Sharpening	11
- Safety Symbols	5	- Supply Cable	11
- Operation	5 - 6	- Storage	11
- Maintenance & Storage	6	Lawn Care Calendar	12
- Control Symbols	6	Trouble Shooting	13
Assembling the Mower Before First Use	7	Warranty	14
- Delivery Checklist	7	Notes	14 - 15
- Handlebar	7	Customer Info / Service Records	16
- Grassbag Assembly	7		
- Grassbag Attachment	7		
- Supply Cable	7		
Operating The Mower	8 - 10		
- Electrical Connection	8		
- Starting	8		
- Forward Travel	8		
- Turning	8		
- Stopping	8		
- Height of Cut	8		
- Before Mowing	8		
- Grassbag	8		
- Without Grass Collection	8		
- Heavy Growth	9		
- Non-Grassed Areas	9		
- Safe Mower Practice	9		
- Overloading Protection	9		
- Maintenance Schedule	10		

INTRODUCTION

Thank you for purchasing a Hayter mower. The following pages are designed to help you gain safe and efficient service from your machine.

IMPORTANT: This 'Owners Handbook' should be regarded as part of the mower as it gives essential information regarding mower safety, operation, maintenance and specifications. Read and understand this handbook prior to operating your mower for the first time. Make sure you are familiar with all the controls and points of regular maintenance. If you have any doubts, consult your local Hayter authorised dealer who will be pleased to give you assistance.

IMPORTANT: This mower is designed solely for use in a domestic grass cutting environment. Use in any other way is considered as contrary to the intended use. Compliance with and strict adherence to the conditions of operation, service and repair as specified in this handbook also constitute essential elements of the intended use. This mower should be operated, serviced and repaired only by persons who are familiar with its particular characteristics and who are acquainted with the relevant safety procedures.

The safety precautions listed in this handbook and all other generally recognised regulations on safety must be observed at all times.

Use of non standard parts or any arbitrary modifications carried out on this machine may relieve Hayter Limited of liability for any resulting damage or injury.

Hayter mowers are robustly constructed and designed for efficient economical performance under normal mowing conditions. Correct operation and maintenance will ensure a long and satisfactory service life. Prior to despatch from our factory every effort is made to ensure that your mower is delivered in perfect condition.

Throughout this handbook all references to **left** and **right** are as viewed from behind the handlebar, in the direction of forward travel.

This handbook is based on information available at the time of publication.

HAYTER LIMITED reserve the right to amend product specifications without prior notification.

For a full range of products and to locate your nearest authorised sales stockist, service or parts dealer please visit our website at www.hayter.co.uk

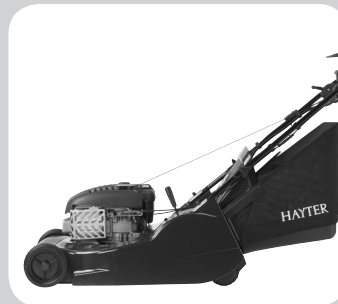

SPECIFICATIONS / MAIN FEATURES

Code	615
Motor Supply	230V
Rated Input	1.5 kW
Cutterblade Speed	2950 rpm
Fuse Rating	13A
Cutting width	410 mm
Cutting height	13 - 65 mm
Overall dimensions	1058 x 476 x 1380 mm
Weight	29 Kg

1. Motor Housing.
2. Serial No. Label.
3. Handlebar Securing Knob.
4. Rear Deflector.
5. Switch Control Unit.
6. Stop Lever.
7. Handlebar.
8. Cable Cleat.
9. Grassbag Assembly.
10. Cable.
11. Height of Cut Lever.

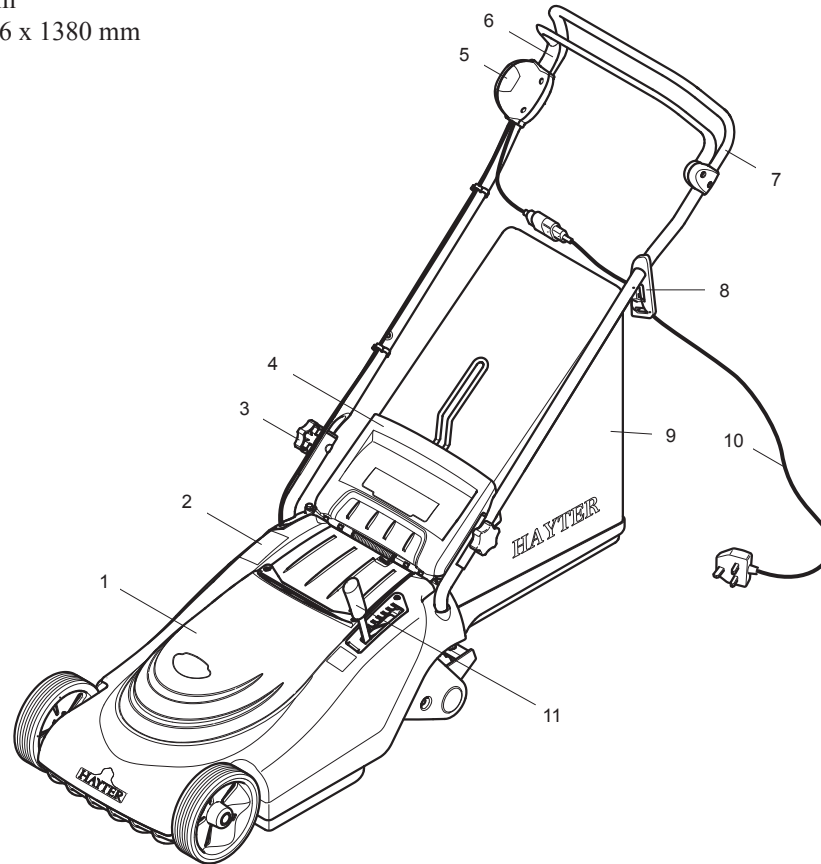

SAFETY PRECAUTIONS

Safety Alert Symbol

This safety alert symbol indicates important safety messages. When you see this symbol be alert to the possibility of injury. Carefully read the following and inform others.

Your mower is perfectly safe if used correctly. Failure to observe the following precautions may result in serious injury.

Training

Before using the mower read the owners handbook carefully. Pay particular attention to the safety precautions. Ensure that you are familiar with the controls and the proper use of the equipment. Learn how to stop the mower quickly in an emergency.

Never allow children or people unfamiliar with these instructions to use the mower. Local regulations can restrict the age of the operator.

Never mow while people, especially children, or pets are nearby.

Keep in mind that the user is responsible for accidents or hazards occurring to other people or their property.

Preparation

It is recommended that a high sensitivity Residual Current - Operated Circuit - Breaker (RCCB) with a trip current of not more than 30mA is installed at the mains socket. This will provide the user with additional protection against electric shock. The fuse installed in the plug only provides protection for the electrical equipment and will not safeguard against electrocution. Always check the RCCB before using the mower.

WARNING: Regularly inspect the supply cable for signs of damage or ageing. Replace immediately if defective.

While mowing, always wear substantial footwear and long trousers. Do not operate the equipment when barefoot or wearing sandals.

Thoroughly inspect the area where the mower is to be used and remove all objects which may be thrown by the machine.

A damaged cutterblade or loose fixing bolt are major hazards. Before use, always visually inspect the cutting mechanism to ensure that it is in good condition. A damaged cutterblade must be replaced immediately with a genuine Hayter replacement part.

Operation

SWITCH OFF AND REMOVE PLUG FROM MAINS:

- Before clearing blockages or unclogging the discharge chute.
- Before cleaning/checking or working on the machine.
- Whenever you leave the machine.
- After striking a foreign object. Inspect the machine for damage and ensure necessary repairs are made before re-starting and operating.
- If the machine starts to vibrate abnormally (check immediately).
- If the supply cable is entangled.

THE CUTTERBLADE CAN CONTINUE TO ROTATE AFTER THE MACHINE IS SWITCHED OFF.

Keep the supply cable clear of the cutterblade at all times.

Do not mow across the supply cable. If this occurs, disconnect the mains supply and check for damage. Do not use a defective supply cable.

Mow only in daylight or good artificial light.

Avoid using the machine on wet grass, where feasible.

Safety Symbols



Safety Alert - Be aware to the possibility of injury.



Carefully read the Owners Handbook before using the machine.



Danger of severing toes or fingers in cutting mechanism.



Wait until all machine components have stopped before touching them



Danger of being hit by thrown objects.

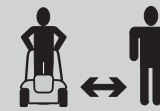

Keep bystanders at a safe distance from the mower.

SAFETY PRECAUTIONS

Operation cont

Always be sure of your footing on slopes.

Walk, never run.

Do not mow excessively steep slopes of more than 20° and mow across the face of slopes, never up and down.

Exercise extreme caution when changing direction.

Use extreme caution when reversing or pulling the mower towards you.

Switch off, if the mower has to be tilted for transportation when crossing surfaces other than grass and when transporting the mower to and from the area to be mowed.

Always replace worn or faulty parts with genuine Hayter parts.

Never operate the machine with defective guards, or without safety devices, for example deflectors and/or grass bag in place.

Do not put hands or feet near or under rotating parts.

Do not tilt the front of the mower more than is absolutely

necessary when starting. Never lift the rear of the mower.

Never pick up or carry a mower whilst it is running or connected to the mains supply.

Do not lift the rear deflector whilst the mower is in operation, particularly when using without a grassbag.

Maintenance & Storage

Keep all nuts, bolts and screws tight to ensure that the equipment is in safe operating condition.

Carefully examine the supply cable for signs of damage or ageing. Replace immediately if defective.

Check the rear deflector and grassbag frequently for wear or deterioration.

Replace worn or damaged parts for safety.

Wear strong work gloves when removing and reassembling the cutterblade.

This machine contains spring loaded assemblies which could cause a hazard when disassembled and re-assembled, this maintenance should only be carried out by a Hayter authorised dealer.

Safety Symbols cont'd



Danger of electrical shock, electrocution



Do not use in rain or in wet conditions



Switch off and remove plug from mains before performing maintenance or repair work



Control Symbols



Switch ON / OFF



Height of Cut Adjustment

ASSEMBLING THE MOWER BEFORE FIRST USE

Delivery Checklist

Remove the mower from the packaging and check that the following items have been supplied correctly. If any items are missing, contact your local Hayter dealer.

1. Motor Handbook.
2. Grassbag Frame.
3. Supply Cable.
4. Grassbag Fabric.
5. Warranty Reg Card.
6. Parts list/D of C.

To prevent accidents cut off the long ribbon attached to the grassbag and discard. *(Refer fig.1)*

Handlebar

Unscrew the handlebar securing knobs sufficiently to allow the handlebar to pivot.

Unfold the handlebar to the operating position.

Tighten all handlebar knobs to secure in position.

(Refer fig.2)

Take care to ensure that the power cable does not become snagged at the pivot points.

Grassbag Assembly

1. Insert the metal frame into the grassbag fabric.

2. Clip into position.

(Refer fig.3)

Grassbag Attachment

Once the grassbag is assembled. Raise the rear deflector, pass the grassbag under the handlebar and hook into position. Lower the rear deflector to rest on the grassbag.

(Refer fig.4)

Supply Cable

Route the supply cable loosely across to the cable cleat on the left side of the handlebar. Make a loop in the supply cable and secure to the cable cleat. *(Refer fig.5)*

Fig. 1

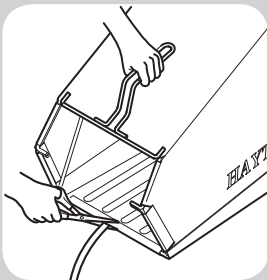

Fig. 2

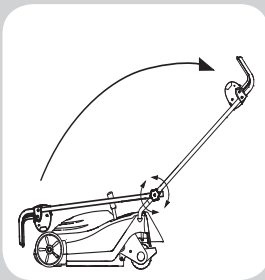

Fig. 3

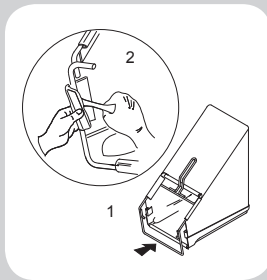

Fig. 4

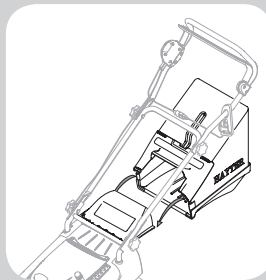
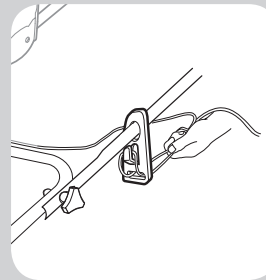

Fig. 5



OPERATING THE MOWER

Electrical Connection

Position the mower on the grass area to be cut. Carefully uncoil the supply cable clear of the mower. Ensure that the mains socket is switch 'OFF' before connecting. Switch 'ON'.

Note: We recommend the use of a RCCB unit. refer to the 'Safety Precautions - Preparation'.

Starting

If you restart the motor after it has been running but before it has come to a complete stop, you could damage the motor making the mower unsafe.

Allow the motor to come to a complete stop before starting it.

Locate the bail arm lever mounted on the handlebar and ensure that your feet are clear of the mower deck. Depress the safety button with the right hand and pull the bail arm towards the handlebar with the left hand. The motor will now start. (Refer fig.6)

Forward Travel

Hold and push against the handlebar with both hands to move the mower forwards. (Refer fig.7)

Turning

To make a wide turn steer the mower with the handlebar in the direction required.

To make a tight turn apply downward pressure on the handlebar to raise the front wheels just above ground level and steer in the required direction.

To prevent accidents do not raise the front of the mower excessively when making a turn. Never raise the rear of the mower when the motor is running.

Stopping

Release the stop lever to stop the motor.

WARNING: AVOID ACCIDENTS - The cutterblade may continue to rotate after the mower is switched off. (Refer fig.8)

Height Of Cut

Move the height of cut lever sideways to disengage it from the locking notch, then push forwards to lower or pull backwards to raise the height of cut. Release the lever in the required position and ensure that it locks firmly into one of the seven notch settings.

Always select a height of cut to suit operating conditions. Prevent motor overloading and blockages by avoiding low cuts in long grass conditions. Be prepared to make

two cuts when the grass is long. (Refer fig.9)

Before Mowing

To prevent accidents, thoroughly inspect the area and remove all objects which when contacted by the mower cutterblade could become dangerous projectiles. Inspect the area for hidden obstructions which when contacted by the cutterblade could risk health and safety or result in damage to the mower. Remember the location of these obstructions and ensure that you mow around them. (Refer fig.10)

Grassbag

Raise the rear deflector and lift the grassbag and lower the rear deflector to rest against the rear of the mower.

To empty the grassbag, pour out the grass clippings and shake the grassbag vigorously to clean the airways. Good grass collection depends on good air flow through the grassbag. When collecting grass clippings it is important that the grassbag is emptied regularly to prevent blockages and engine overloading. (Refer fig.11)

Without Grass Collection

Remove the grassbag and operate the mower with the rear deflector in the closed position. (Refer fig.12)

Fig. 6

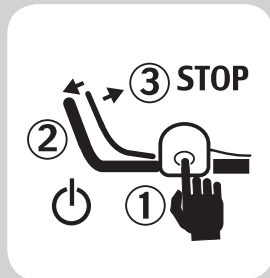

Fig. 7

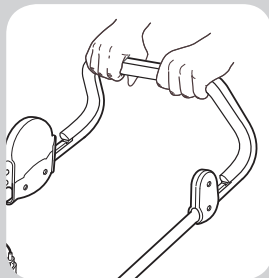

Fig. 8

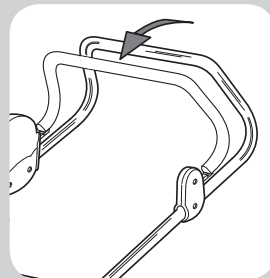

Fig. 9

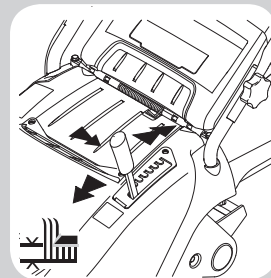

Fig. 10

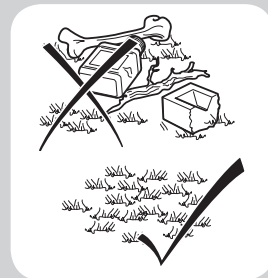

Fig. 11

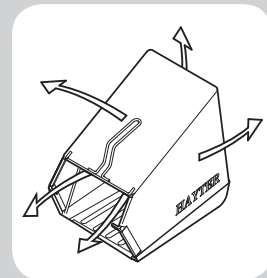
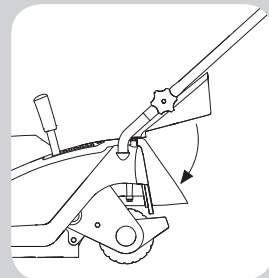

Fig. 12



OPERATING THE MOWER

Heavy Growth

Areas of heavy growth should be mown without collecting the clippings. If collection is required, first mow the area without the grassbag at the maximum height of cut setting. Allow the grass clippings to dry out and then mow the area at the maximum height of cut setting with the grassbag fitted. Reduce the height of cut and mow the area again as necessary until the required finish is obtained.

To prevent damage to your lawn do not remove more than one third of grass height in one cut. (Refer fig.13)

Non Grassed Areas

When moving the mower across non-grassed areas, stop the motor and set the mower to the maximum height of cut to protect the cutting mechanism.

Safe Mower Practice

WARNING: PREVENT ACCIDENTS - Take extreme care not to mow across the supply cable. If this should occur, switch off immediately and disconnect the plug from the power supply. Carefully examine the cable for cuts and damage. A defective cable must be replaced before the mower is used again. Always be aware of the location of the supply cable in relation to the mower and the grass area. Do not allow the cable to become hidden in uncut grass. Keep the cable over the cut area at all times. A cable which is out of sight, is out of mind and

this could lead to hazardous situation.

Plan a 'cutting scheme' which works away from the power supply point and ensures that the cable is trailed out over the cut area. Work up and down the lawn in rows. Turn the machine round at the end of the row and step across the cable so that the cable is trailed along in the cut area on the return run.

When working around flower beds, prevent the cable from trailing across cultivated area by positioning a stake at the corner of the bed. Do not allow the cable to be pulled around sharp obstructions. Stop mowing immediately if cable resistance is felt and remove the obstruction. Do not allow the cable to become entangled.

WARNING: PREVENT ACCIDENTS - Switch off at the mains, remove the plug before adjusting, cleaning or if the cable is entangled.

Overloading Protection

Do not let the motor labour or slow down through being overloaded in work. When this situation occurs, raise the front of the mower slightly by bearing down on the handlebar, allow the motor to reach maximum speed and proceed to mow at a slower pace. Alternatively re adjust to a higher cut position. If the motor continues to labour, switch off and remove the plug from the mains supply. Remove and empty the grassbag. Examine the discharge

chute and remove any blockage. Turn the machine on its side and clear the obstruction from the cutterblade and the underside of the mower deck. Place the machine upright and replace the grassbag. Re adjust to a higher cut position if necessary. Re start the mower and proceed to mow at a pace which does not over the mower.

IMPORTANT: PREVENT DAMAGE - DO NOT continue to operate the motor in an overload condition. If this does occur, stop mowing and allow the motor to run at maximum speed for one minute. This will allow the motor to cool down to its normal working temperature.

Fig. 13

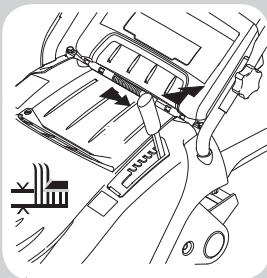

MAINTENANCE SCHEDULE / MOWER MAINTENANCE

Maintenance Schedule

Follow the hourly or calendar intervals, whichever occurs first. More frequent service will be required if working for prolonged periods under dusty, dry conditions, when airborne debris is present or after extensive operation cutting tall, dry grass.

Daily

- Clean grass debris from the height of cut ratchet, air filter in the cowl and the underside of the deck housing.
- Check the condition of guards and safety devices.
- Check condition of cutterblade.
- Check condition of grassbag and ensure airways are clear (replace if damaged).

25 - 50 Hours Or Every Season

- Lubricate pivot points and linkages with oil.
- Check the cables / switch and connection.
- Sharpen the cutterblade.
- Flash test (Dealer) to ensure complete safety.

Grassbag

Remove grass debris from the grassbag immediately after use and check its condition for signs of damage. To prevent accidents replace a damaged grassbag immediately. (Refer fig.13)

Deck Housing

Remove grass debris from the top and underside of the deck housing immediately after use. (Refer fig.14)

Fertilisers and top dressings are particularly corrosive. Thoroughly clean the mower deck immediately after use on treated grass and store well away from corrosive materials.

Securing Nuts & Bolts

Regularly check that all securing nuts and bolts are tight. Replace missing or damaged items immediately.

Bolt - Cutterblade fixing torque 20Nm
General screws - Used on plastic parts 1.5Nm
(Note: Use manual hand tools only)

Lubrication

Lubricate the pivot points and linkages with oil every 25 operating hours.

Cutterblade Removal

Turn the mower on it's side.

Firmly grip the end of the cutterblade (2) with a gloved hand and remove bolt (1). When replacing, ensure that the new cutterblade is the correct way up with the turned edges facing towards the motor before locating onto

the two carrier pins. Secure the cutterblade fixing nylon bolt and tighten to the specified torque of 20Nm. (Refer fig.15)

The cutterblade has sharp edges. ALWAYS wear strong gloves to protect your hands when working on the cutterblade. DO NOT rotate tools towards the cutting edges to avoid the risk of injury should the tool slip. ALWAYS use genuine Hayter replacement parts.

The condition of the cutterblade and its mounting arrangement should be checked regularly for signs of wear or damage. Ensure that the cutterblade is not bent or cracked.

A damaged cutterblade that is out of balance will vibrate excessively and may break. DO NOT use an unbalanced cutterblade.

Regularly check that the bolt securing the cutterblade is tightened to the specified torque of 20Nm.

Replace the cutterblade every 2 years or sooner or excessively worn or damaged.

Fig. 13

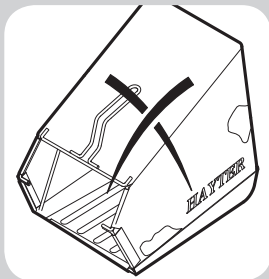

Fig. 14

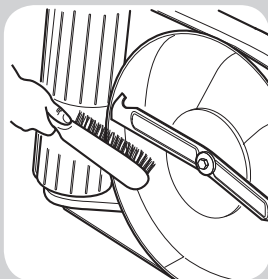
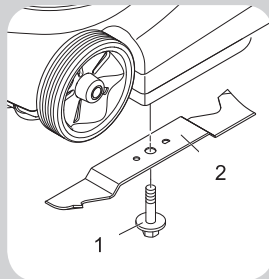

Fig. 15



MOWER MAINTENANCE

Cutterblade Removal

To prevent injury it is wise to seek assistance when turning the mower on its side.

Cutterblade Sharpening

A slightly worn cutterblade may be re-sharpened. Both blade edges must be sharpened equally to ensure balance. Sharpen the cutterblade every 25 mowing hours or more frequently if conditions require. Remove the cutterblade from the mower and clean using a brush and water. Inspect the cutterblade for signs of damage. Sharpen both cutting edges with a flat file to restore performance. **(Refer fig.16)**

Ensure that the cutterblade is balanced. Use a screw driver with a round shaft to support the cutterblade through its centre hole. Hold the cutterblade horizontal and then release. A balanced cutterblade will remain horizontal. **(Refer fig.17)**

If the cutterblade is not balanced the heavy end will rotate downwards. Sharpen the heavy end until the cutterblade is correctly balanced. **(Refer fig.18)**

Supply Cable

Check the condition of the supply cable for damage or ageing. Replace immediately if defective.

Storage

To collapse the handlebar, first unscrew the two top securing knobs to allow the top section of the handlebar to pivot forward to rest against the middle section. Unscrew the bottom two securing knobs sufficiently to allow both top and middle sections to be folded forwards.

To ensure that your mower is maintained in good working order, it is important that the following procedure is adopted when the mower is stored for periods in excess of one month. Refer to the 'Maintenance' section as necessary.

Clean all areas of the mower and ensure that the grassbag is clean.

Lubricate the mower.

Treat metal parts with a water repellent anti-corrosion product.

Lower the handlebar if desired.

Cover the mower with a protective sheet and store in a dry area.

Rest the mower deck on wooden blocks to remove the weight of the mower from its wheels/roller. **(Refer fig.19)**

CAUTION - PREVENT ENVIRONMENTAL DAMAGE. **(Refer fig.20)**

EU Directive 2002/96/EC classifies this product as an electrical or electronic equipment.

(a) These products should not be disposed of as unsorted municipal waste. **(Refer fig.20)**

(b) They should be taken to a designated collection point or recycling centre and handled according to national laws in the area.

(c) The consumer has a critical role in returning waste electronic/electrical equipment for recycling and disposal.

(d) Recycling keeps these products out of the municipal waste stream.

(e) The crossed-out bin symbol is a reminder to follow these points.

(f) Please contact your local authority or local dealer and ask for further details regarding the correct method of disposal.

Fig. 16

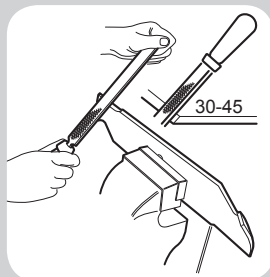

Fig. 17

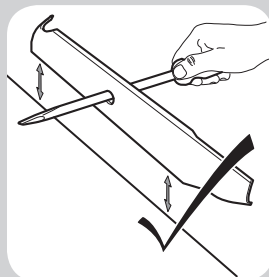

Fig. 18

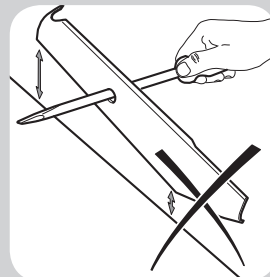

Fig. 19

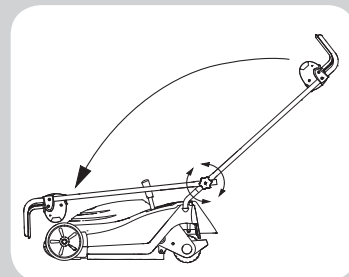

Fig. 20



LAWN CARE CALENDAR

To be used as a guide only

January

There is very little work to do this month apart from brushing away leaves. Keep off the grass if frozen or waterlogged.

February

Rake the grass thoroughly. Spike the lawn to aerate and stimulate soil organisms and root growth and apply lawn sand if necessary.

March

The yearly lawn work programme really starts this month. As soon as the ground conditions are suitable, the first cut can be made. The first cut should merely "top" the grass as close cutting at this stage could result in severe yellowing or browning. Two cuts are generally sufficient this month.

April

Mow often enough to stop grass growing away. Dig out patches of coarse grass or resistant weed. Re-seed bare patches.

May

Keep mowing increasing the frequency as required. Treat with selective weed killers or combined weed/feed preparations if you did not feed the lawn in April.

June

Summer mowing should now be under way. It should be necessary to mow the lawn twice a week. Raking before mowing is important this month as the combined action keeps runners of clover under control. Water the grass if necessary, and remember to soak thoroughly.

July

Treat the grass with the second application of fertiliser or weed killer/fertiliser. Water when necessary and rake occasionally. As a general rule the grass clippings should be removed each time you mow. If weather conditions are dry and hot and the grass is weed free, leave the clippings on the lawn to help maintain ground moisture.

August

Keep mowing regularly and watering as necessary. Fill any cracks caused by drought with a mixture of sharp sand and soil. In dry weather conditions leave the grass longer to help retain ground moisture.

September

Raise the height of cut to allow the grass to thicken and protect the roots from the winter frost and snow.

October

Rake out the thatch from the turf and spike the lawn to assist in drainage. Brush in peat and sharp sand.

November

Use a stiff broom to disperse worm casts before mowing. Keep turf free from leaves.

December

Apart from brushing away leaves, December is a slack end of a busy year. Keep off the lawn if it is very wet or frozen.

Lawn Stripes

The way to achieve a neat striped effect is for the lawn being cut in parallel stripes, alternate stripes being mown in opposite directions. A much more important routine is to cut at right angles to the line of the previous mowing. If the work has been carried in a north-south line, then the next cutting should be in an east-west direction. The cross-cutting keeps down the coarse weed grasses.

To prevent grass damage do not remove more than one third of the grass height in one cut.

TROUBLE SHOOTING

PROBLEM	CAUSES	CORRECTIVE ACTION
Motor fails to start	<ol style="list-style-type: none"> 1. Mains supply socket dead 2. RCCB tripped 3. Plug pulled out of mains socket 4. Fuse failure 5. Supply cable damaged 6. Cutterblade obstructed 	<ol style="list-style-type: none"> 1. Test socket by plugging in another appliance 2. Remove mower plug and check RCCB action. Check the supply cable for any obvious signs of damage and replace immediately if defective. 3. Re engage plug 4. Fit a new amp fuse 5. Disconnect from the mains and check the supply cable for any obvious signs of damage. Replace immediately if defective 6. Disconnect from the mains and remove any obstruction
Motor will not stop	<ol style="list-style-type: none"> 1. Faulty switch control unit 	<ol style="list-style-type: none"> 1. Ensure that the switch lever has returned to the 'OFF' position. Disconnect from the mains and contact your Hayter dealer.
Cutterblade runs on excessively after switching 'OFF'	<ol style="list-style-type: none"> 1. Faulty brake unit 	<ol style="list-style-type: none"> 1. Contact your Hayter dealer
Motor vibrates excessively	<ol style="list-style-type: none"> 1. Mounting bolt loose 2. Cutterblade bolt loose 3. Cutterblade out of balance 	<ol style="list-style-type: none"> 1. Tighten bolts 2. Tighten bolt 3. Balance cutterblade
Uneven cut	<ol style="list-style-type: none"> 1. Undulating ground contours 2. Cutterblade worn 3. Cutterblade out of balance 4. Wheels/roller damaged 	<ol style="list-style-type: none"> 1. Change direction of travel 2. Sharpen the cutterblade 3. Balance cutterblade 4. Inspect and replace as necessary

PROBLEM	CAUSES	CORRECTIVE ACTION
Discharge chute blocks	<ol style="list-style-type: none"> 1. Grass is wet 2. Cut height too low 3. Grassbag full 4. No airflow through the grassbag 	<ol style="list-style-type: none"> 1. Mow dry grass 2. Increase cut height 3. Empty grassbag 4. Clean the grassbag
Mower is hard to push	<ol style="list-style-type: none"> 1. Cut height too low 2. Wheels/roller damaged 	<ol style="list-style-type: none"> 1. Increase cut height 2. Inspect and lubricate or replace as necessary
Poor grass condition	<ol style="list-style-type: none"> 1. No airflow through the grassbag 2. Discharge chute blocked 3. Wet grass 4. Grassbag full 	<ol style="list-style-type: none"> 1. Clean the grassbag 2. Remove blockage 3. Mow dry grass 4. Empty grassbag

Hayter Limited warrants to the original user/purchaser that this unit shall be free from defects in material and workmanship under normal use and service for a period of **three years** from the date of purchase. The manufacturer of major proprietary components ie. engines, gearbox / transaxle (where applicable) furnish their own warranty and services are provided through their authorised network. To qualify for the full benefit of the warranty, the warranty registration card **must** be returned within **14 days** of purchase. Subject to the conditions and exclusions noted in this limited warranty, we shall at our option, repair or replace any warranted part during the applicable period. If you are in doubt or experience any difficulty, please consult a Hayter Authorised Service Dealer for clarification.

To qualify for the extended warranty (second and third year) of the **three year limited warranty** the machine **must** have annual services carried out by an Authorised Hayter Service Dealer. These chargeable services should be carried out within 12 and 24 months of the date of purchase.

Excluded from the extended warranty period are those items which are subject to normal wear and tear e.g. tyres, wheels, cutterblades, belts, cables, grassbags, sweeper/brushes, batteries and other consumable wearing parts.

All consumer machines which are fitted with a **genuine** Hayter friction disc as original equipment before use, are covered by a **Lifetime Warranty** against the engine crankshaft bending. **Note:** friction washers, blade brake clutch (B.B.C) units and other such devices are not applicable. Only machines fitted with a **genuine** Hayter friction disc, which are used in accordance with the recommended operating and maintenance procedures, are covered.

This warranty does not apply to any unit that has been tampered with, altered, misused, abused or used for hire, and will become invalid if non genuine Hayter parts are fitted. This warranty does not cover minor mechanical adjustments unless they are due to defective material or workmanship. Consult the Owner's Handbook or a Hayter Authorised Service Dealer for assistance when making these adjustments.

A warranty period of 90 days applies to machines used for commercial purposes.

To make a warranty claim, return the unit to a Hayter authorised dealer along with proof of purchase stating the machine serial number and date of purchase. The service receipt(s) or this Owners Handbook with the 1st/2nd year service boxes fully completed, must be produced as proof of entitlement to the extended warranty period. Subject to the conditions and exclusions in this limited warranty, the authorised dealer will, at our option, repair or replace any warranted part within the duration of the warranty period.

This limited warranty gives you specific legal rights and is in addition to any statutory rights to which you may be entitled and your statutory rights are not affected by this warranty. If you need additional information concerning this written warranty, or assistance in obtaining services, please write to : **HAYTER LIMITED, Service Department, Spellbrook, Bishop's Stortford, Hertfordshire CM23 4BU**

UK ONLY: Details of your local **Hayter** authorised dealer are contained in Yellow Pages and the Hayter website www.hayter.co.uk or contact contact:- Freephone 0800 616298.

Issue: 01.09.09

CUSTOMER INFORMATION

CODE

SERIAL NO.

Motor Type:- 240V

Date of Sale:- _____

Your Local Dealer:-

DEALER STAMP



Hayter Limited, Spellbrook, Bishop's Stortford, Herts, CM23 4BU, England
Website: www.hayter.co.uk

SERVICE RECORD



1st Year (12 months)

We certify that this service has been carried out by an Authorised Hayter Service Dealer

Date: _____

DEALER STAMP



1st Year (12 months)

Owner's Name: _____

Serial Number: _____

Date: _____

DEALER STAMP

Note for dealer: Please retain this voucher for your records.



2nd Year (24 months)

We certify that this service has been carried out by an Authorised Hayter Service Dealer

Date: _____

DEALER STAMP



2nd Year (24 months)

Owner's Name: _____

Serial Number: _____

Date: _____

DEALER STAMP

Note for dealer: Please retain this voucher for your records.

